



**Engineering and Design
Best practices for manufacturing (Airconditioning)
tubes & hose assemblies**

Specification nr.	Rev.	Date	Author	Refrigerant	Signature	Page
BUR-SPEC-001	G	26-03-2018	Engineering	R134a R1234yf		1/25



- 1.0 Scope
- 2.0 Applicable
- 3.0 Responsibility
- 4.0 Drawings
- 5.0 Material
 - 5.1 Tubing
 - 5.1.1 Specifications
 - 5.1.1.1 Steel
 - 5.1.1.2 Aluminium
 - 5.1.1.3 Aluminium Internal Heat Exchanger
 - 5.1.2 Tubing sizes
 - 5.1.2.1 Tubing size steel or steel passivated
 - 5.1.2.2 Tubing size aluminium
 - 5.2 Hose
 - 5.2.1 Specifications
 - 5.2.2 Hose size
 - 5.2.2.1 Standard barrier 3055
 - 5.2.2.2 Reduced barrier 3090
 - 5.2.3 Tolerance
 - 5.2.4 Working pressure
 - 5.2.5 Minimum burst pressure
 - 5.2.6 Bend radii
 - 5.2.6.1 Bend radii standard barrier 3055
 - 5.2.6.2 Bend radii reduced barrier 3090
 - 5.3 Refrigerants and oils
- 6.0 Bending specifications
 - 6.1 Flattening tube
 - 6.2 Position of XYZ coordinates
 - 6.3 Points of XYZ coordinates on a product
 - 6.4 Bend Radii tubing
 - 6.4.1 Bend radii steel or passivated steel tubing
- 7.0 Machined parts
 - 7.1 Specifications material
 - 7.2 Tolerance braze chamber
 - 7.3 Valve bodies R134a – R1234yf

	Paraaf
Checked: Quality Manager	
Approved: Managing Director	

**Engineering and Design
Best practices for manufacturing (Airconditioning)
tubes & hose assemblies**

Specification nr.	Rev.	Date	Author	Refrigerant	Signature	Page
BUR-SPEC-001	H	13-01-2023	Engineering	R134a R1234yf		2/25

- 8.0 Fitting and tubing design best practice
 - 8.1 End form
 - 8.2 O-ring connection
 - 8.2.1 O-ring pilot steel
 - 8.2.2 O-ring pilot aluminium
 - 8.2.3 O-ring nut
 - 8.2.4 O-ring and torque
- 9.0 Plating
 - 9.1 Burgaflex standard Cr6free
 - 9.2 Zink nickel
- 10.0 Dimensions fittings
 - 10.1 Catalogues
 - 10.2 Run and drop
 - 10.3 Part numbering
- 11.0 Hose and crimp design best practice
 - 11.1 Length and tolerance
 - 11.2 Hose length specification
 - 11.3 Crimping
 - 11.4 Indicate the angle between two fittings
- 12.0 Validation and quality control tests
 - 12.1 Burst pressure test
 - 12.2 Coupling integrity test
 - 12.3 Corrosion resistance test
 - 12.4 Cleanliness test
- 13.0 Identification
- 14.0 Leak test
 - 14.1 Burgaflex Standard
 - 14.2 Process of testing
- 15.0 Engineering
 - 15.1 CAD system

		Engineering and Design Best practices for manufacturing (Airconditioning) tubes & hose assemblies				
Specification nr.	Rev.	Date	Author	Refrigerant	Signature	Page
BUR-SPEC-001	H	13-01-2023	Engineering	R134a R1234yf		3/25

1.0 Scope

The aim of this document is to illustrate the current best engineering practices for manufacturing tubing, fittings and hose assemblies by Burgaflex BV - The Netherlands, Burgaflex UK Ltd – United Kingdom, Burgaflex Poland Sp. Zoo, Burgaflex France SAS and Burgaflex Turkey Ltd – Turkey. Please consult your facility for the deviations.

2.0 Applicable

Complete production process Burgaflex BV - The Netherlands.



Hoses: -06 (ID 7,9 mm) up to -14 (ID 19 mm)
 Tubes: Imperial: -06 (OD 9,52 m up to -12 (OD 19,05 mm)
 Metric -6 mm up to 38 mm

3.0 Responsibility

Engineering is responsible for the maintenance and update of this document.

4.0 Drawings

Burgaflex drawings are based on American projection

	Engineering and Design Best practices for manufacturing (Airconditioning) tubes & hose assemblies					
	Specification nr.	Rev.	Date	Author	Refrigerant	Signature
BUR-SPEC-001	H	13-01-2023	Engineering	R134a R1234yf		4/25

5.0 Material

5.1 Tubing

5.1.1 Specifications.

5.1.1.1 Steel

Standard steel tubing used in production is seamless according EN10305-1 Material E235 + N or seamless passivated tube is according to SAE524 - material J524 - Chr6Fr passivated.

5.1.1.2 Aluminium

Standard in imperial (inch) sizes:

Aluminium alloy according to specifications EN AW-3103 acc. to EN 573-3, 2009 (E)

Temper H12 acc. to EN 754-2, 2008 (E). Geometrical tolerances according EN 13958, 2008 (E) (also available in EN AW5049)

Standard in metric sizes:



Aluminium alloy according to specifications EN AW5049 seawater resistance

5.1.1.3 Aluminium Internal Heat Exchanger

Outer tube: Extruded aluminium profile, alloy EN AW 3103, according to DIN EN 573/3 (08/2009)
Dimension: 25x1,4 mm.

Inner tube: Aluminium alloy according to specifications EN AW-3103 acc. to EN 573-3, 2009 (E)
Dimensions: 19,05x1,24 mm



		Engineering and Design Best practices for manufacturing (Airconditioning) tubes & hose assemblies				
Specification nr.	Rev.	Date	Author	Refrigerant	Signature	Page
BUR-SPEC-001	H	13-01-2023	Engineering	R134a R1234yf		5/25

5.1.2 Tubing sizes

Size standardization reduces cost through decreased material inventory and increased purchasing volumes. To help achieve this goal, the recommended tube sizes listed in the tables below should be used if possible.

5.1.2.1 Tubing size steel or Steel passivated



Imperial (Inch) Standard used for Burgaflex production

Size	Inch	Outer diameter X wall thickness (mm)
6	3/8	9,52 x 0,89 (*)
		9.52 x 1.24
8	1/2	12,7 x 0,89 (*)
		12,7 x 1.24
10	5/8	15,88 x 1,24
12	3/4	19,05 x 1,24

(*) Standard dimension used

Metric By request

Size	Metric	Outer diameter X wall thickness (mm)
6	10 mm	10 x 1
8	12 mm	12 x 1
10	16 mm	16 x 1
12	20 mm	20 x 1

		Engineering and Design Best practices for manufacturing (Airconditioning) tubes & hose assemblies				
Specification nr.	Rev.	Date	Author	Refrigerant	Signature	Page
BUR-SPEC-001	H	13-01-2023	Engineering	R134a R1234yf		6/25

5.1.2.2 Tubing size aluminium

AW3031 (eq. AW5049) Imperial (Inch). Standard used for Burgaflex production



Size	Inch	Outer diameter X wall thickness (mm)
6	3/8	9,52 x 1,24
8	1/2	12,7 x 1,24
10	5/8	15,88 x 1,24
12	3/4	19,05 x 1,24

AW5049 Metric. By request

Size	Metric	Outer diameter X wall thickness (mm)
6	10 mm	10 x 1,25
8	12 mm	12 x 1.25
10	16 mm	16 x 1,25
12	20 mm	20 x 1,25

5.1.2.3 Ferules

Steel ferules are made in EN 10130: 2006 (number 1.0338) Cold rolled low carbon steel

		Engineering and Design Best practices for manufacturing (Airconditioning) tubes & hose assemblies				
Specification nr.	Rev.	Date	Author	Refrigerant	Signature	Page
BUR-SPEC-001	H	13-01-2023	Engineering	R134a R1234yf		7/25

5.2 Hose

5.2.1 Specifications.

Most common standard hose (3055) or reduced barrier hose (3090). Both hoses used are according the specifications SAE J3062 rev 2015. The hoses coupled with Burgaflex crimp fittings or Burgaclip fittings meets the SAE J2064 rev 2015, ISO 8866-2 or customer specific approvals. For detailed information consult the Burgaflex engineers.

5.2.2 Hose sizes

The hose dimensions given in the tables below are nominal.

5.2.2.1 Standard barrier - 3055 -



Size	Inch	Inner diameter (mm)	Outer diameter (mm)
6	5/16	7,9	18.3
8	13/32	10.3	22.4
10	1/2	12.7	24.6
12	5/8	15.9	27.7

5.2.2.2 Reduced barrier - 3090 -

Size	Inch	Inner diameter (mm)	Outer diameter (mm)
6	5/16	7.9	14.7
8	13/32	10.3	17.30
10	1/2	12.7	19.4
12	5/8	15.9	23.60
14	3/4	19	28.5

5.2.3 Tolerance

The tolerances of Burgaflex hose vary per size. For detailed information consult the hose specification of the hose in question or download from www.burgaflex.com

		Engineering and Design Best practices for manufacturing (Airconditioning) tubes & hose assemblies				
Specification nr.	Rev.	Date	Author	Refrigerant	Signature	Page
BUR-SPEC-001	H	13-01-2023	Engineering	R134a R1234yf		8/25

5.2.4 Working pressure

The working pressure of Burgaflex hose varies per type. For detailed information consult the hose specification of the hose in question or download from www.burgaflex.com

5.2.5 Minimum burst pressure

The minimum burst pressure of Burgaflex hose varies per type. For detailed information consult the hose specification of the hose in question or download from www.burgaflex.com

5.2.6 Bend radii



Bending radii are defined in the tables. Smaller radii are not possible to prevent collapsing of the hose.

5.2.6.1 Bend radii standard barrier - 3055 -

Size	Inch	Minimum Bend Radius (mm)
6	5/16	102
8	13/32	114
10	1/2	127
12	5/8	165

5.2.6.2 Bend radii reduced barrier - 3090 -

Size	Inch	Minimum Bend Radius (mm)
6	5/16	51
8	13/32	64
10	1/2	76
12	5/8	102
14	3/4	250

		Engineering and Design Best practices for manufacturing (Airconditioning) tubes & hose assemblies				
Specification nr.	Rev.	Date	Author	Refrigerant	Signature	Page
BUR-SPEC-001	H	13-01-2023	Engineering	R134a R1234yf		9/25

5.1 Refrigerants and Oils

All hose fitting combinations are burst pressure and coupling integrity tested according the SAE J2064 rev. 2015, ISO 8866-02 and customer specific requirements. In the table below the different refrigerants and oil combinations which passed the tests.

3055 hose with crimp fittings

R134a and PAG oil



3090 hose with crimp fittings

R134a and PAG oil
R1234yf with PAG and ND oil
R513a and PAG oil
R404a and POE oil
R410a and POE oil
R452a and POE oil



3090 hose with Burgaclip fittings

R134a and PAG oil
R1234yf with PAG and ND oil
R513a and PAG oil
R404a and POE oil
R410a and POE oil
R452a and POE oil

For detailed information please consult our engineers.

Burgaflex		Engineering and Design Best practices for manufacturing (Airconditioning) tubes & hose assemblies				
Specification nr.	Rev.	Date	Author	Refrigerant	Signature	Page
BUR-SPEC-001	H	13-01-2023	Engineering	R134a R1234yf		10/25

6.0 Bending specifications

6.1 Flattening tube

The maximum flattening of the tube is specified in BURG SPEC 003. The maximum flattening of the diameter of the tube after bending is 18 %. No folds in the inside curve, no cracks or beginning cracks visible and no sharp tool marks on the tube.

6.2 Position of X, Y, Z coordinates on a drawing

When positioning the xyz coordinates on a drawing, the end points should be marked according to figures below. The connections area indicates the XYZ coordinates

These points designate end of tube or point of interface with hose component.

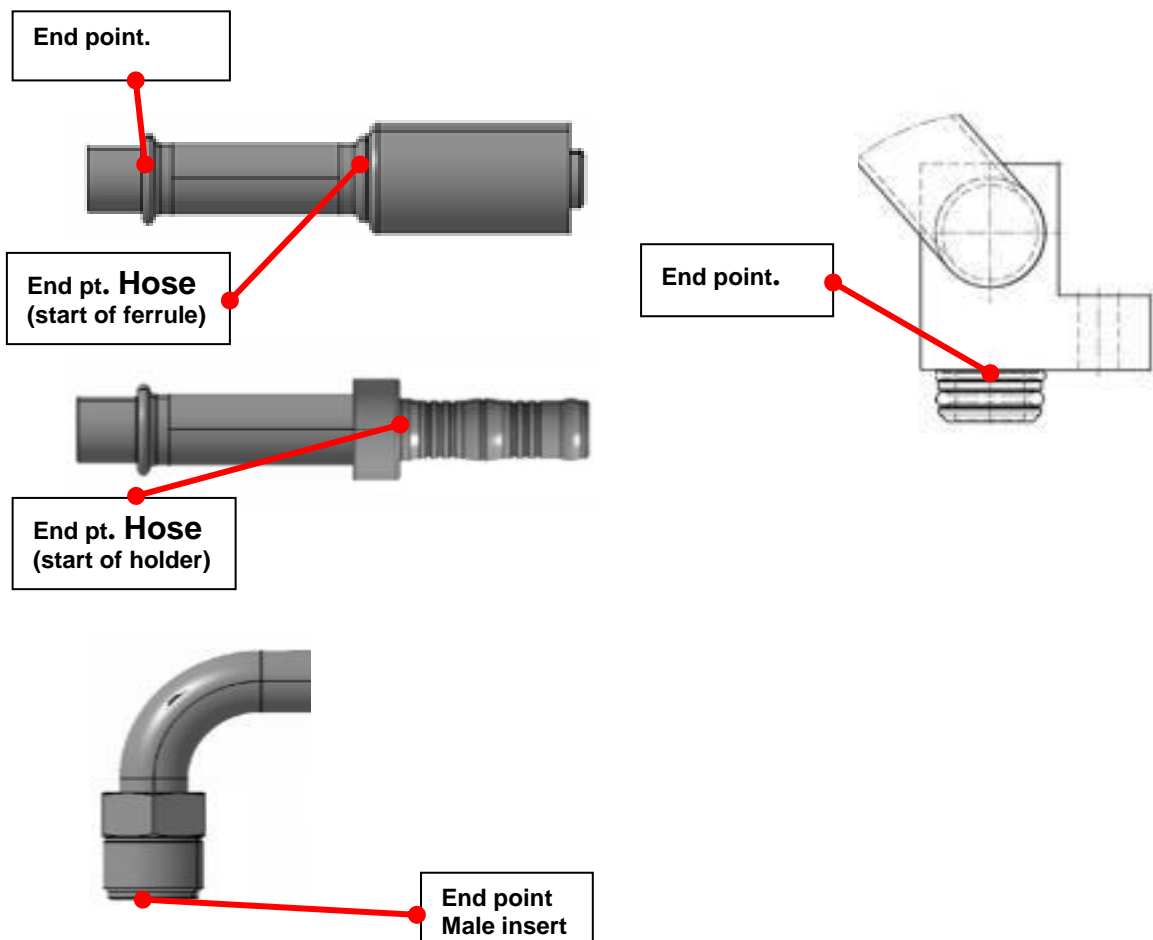

Specification nr.	Rev.	Date	Author	Refrigerant	Signature	Page
BUR-SPEC-001	H	13-01-2023	Engineering	R134a R1234yf		11/25

6.3 Points of X, Y, Z coordinates of a part

The X, Y, Z coordinates are written down in a XYZ table. The position of the XYZ coordinates according the example below.

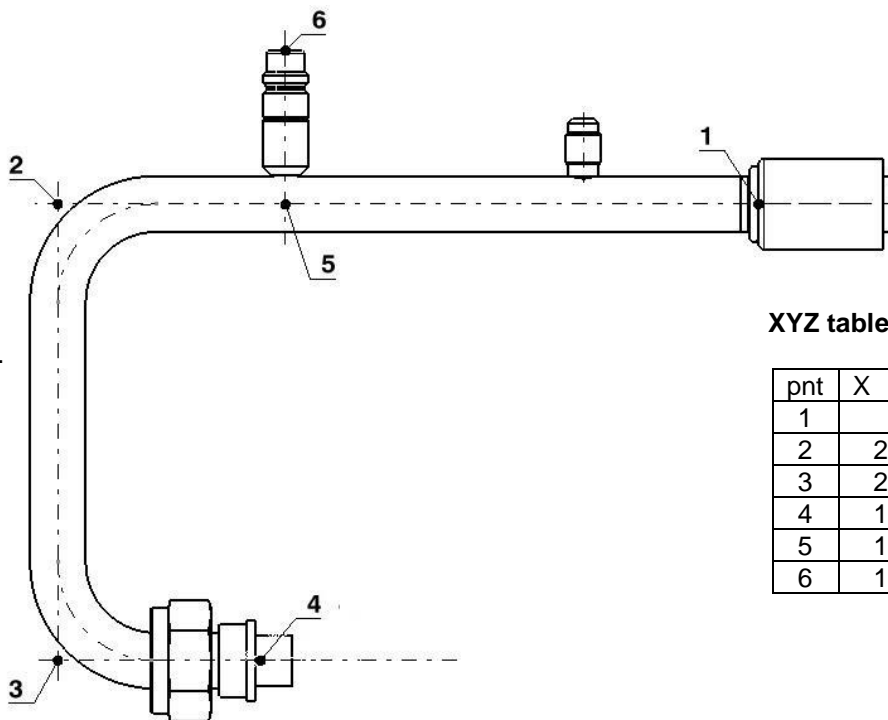

XYZ table

pnt	X	Y	Z
1	0	0	0
2	200	0	0
3	200	130	0
4	154	130	0
5	132	0	0
6	135	-43.56	0

Important: points 5 and 6 define the position of the valve and the angle of the valve.

6.3.1 General tolerances bending proces.

Burgaflex uses a Best Fit Method for bending tubes without flanges and Fixed Point Best Fit Method with flanges. Within the Bending process hereunder are the general tolerances for bending.

Tube length	XYZ data	YBC	End to End
< 2 meter	±3 mm	±3 mm	±3 mm
> 2 meter	±5 mm	±5 mm	±5 mm

Specification nr.	Rev.	Date	Author	Refrigerant	Signature	Page
BUR-SPEC-001	H	13-01-2023	Engineering	R134a R1234yf		12/25

6.4 Bend radii tubing

Bending radii and minimal straight pipe ends are defined in table below. Main rule for minimum bend radius is two times pipe diameter. Smaller radii are not possible to prevent collapsing of the pipe bend. The straight ends are necessary for grip on the bending machine. Minimum distance between bend radii shall not exceed diameter of tube

6.4.1 Bend radii

Size	Ø	Minimum Bend radius / Straight end		
Imperial	MM	In between 1,5*Diameter 2*Diameter		Basic Bend Radius
6 (3/8")	9,52	14,28	19,04	20
8 (1/2")	12,7	19,05	25,4	25
10 (5/8")	15,88	23,82	31,76	25
12 (3/4")	19,05	28,575	38,1	30
1"	25,4	38,1	50,8	
Metric	MM	In between 1,5*Diameter 2*Diameter		Basic Bend Radius
6	6	9	12	15
8	8	12	16	15
10	10	15	20	15
12	12	18	24	20
14	14	21	28	28
15	15	22,5	30	25
16	16	24	32	25
18	18	27	36	25
20	20	30	40	40
22	22	33	44	35
28	28	42	56	80
35	35	52,5	70	65
38	38	57	76	

* Basic rule, not standard and depending on routing of tubing. Please consult your facility
The general tolerance on the bending radii is ± 5 mm

Specification nr.	Rev.	Date	Author	Refrigerant	Signature	Page
BUR-SPEC-001	H	13-01-2023	Engineering	R134a R1234yf		13/25

6.4.2 Bend radii IHX

Size	ø (mm)	Thickness (mm)	Radius (mm)				Min. Straight before or after bend end* (= +/- 1,5 x diameter tube)
			1	2	3	4	
Outer Tube							
25	25	1,4	50				25
Inner Tube							
12	19,05	1,24	30	35			28,6

* Basic rule, not standard and depending on routing of tubing. Please consult your facility

Specification nr.	Rev.	Date	Author	Refrigerant	Signature	Page
BUR-SPEC-001	H	13-01-2023	Engineering	R134a R1234yf		14/25

7.0 Machined parts

Machined parts are produced against drawings released by Burgaflex or based on customer specific drawings. Dimensions and tolerances are specified on the drawing.

7.1 Specifications material

If material is not specified on the drawing the following material is standard specified for machined parts:

- Steel Steel 37 (11 SMnPb30C)
- Aluminium: EN AW 6082 (A1Si1MgMn)

7.2 Tolerance braze chamber

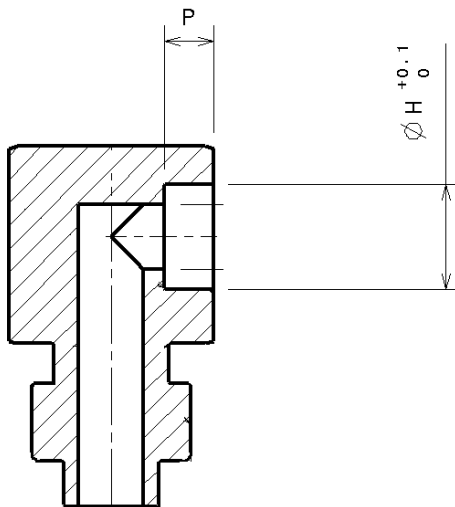

To make a good brazing connection the depth of the braze chamber (P) should be 6 mm at the minimum. Size H needs to be according to the tolerance corresponding – see table



Dimension tube	H (mm)
9,52	9,6
12,7	12,8
15,88	16,0
19,05	19,1

The recommended minimal distance for brazing a valve or pipe on the outside diameter of a pipe is 30 mm from both the crimp ferrule and bend. Preferably the valve or pipe should be put on a straight end of a pipe. Brazing in bends is possible but could lead to larger tolerances

For oven brazing the brazing chamber needs to be the OD size of the tube.

		Engineering and Design Best practices for manufacturing (Airconditioning) tubes & hose assemblies				
Specification nr.	Rev.	Date	Author	Refrigerant	Signature	Page
BUR-SPEC-001	H	13-01-2023	Engineering	R134a R1234yf		15/25

7.2 Valve bodies R134a and R1234yf

to distinguish the difference in valve bodies for R123a and R1234yf Burgaflex added a specific ring on the R134a valve body as shown in the picture. Without the ring the application is applicable for R1234yf.

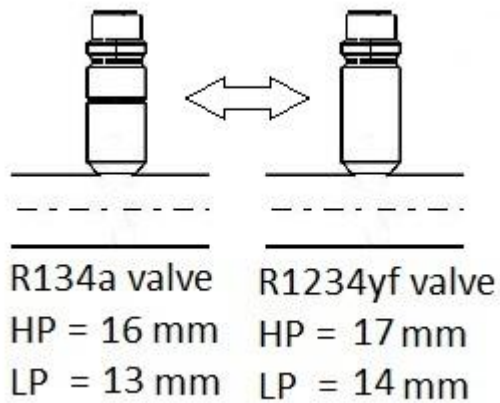

Specification nr.	Rev.	Date	Author	Refrigerant	Signature	Page
BUR-SPEC-001	H	13-01-2023	Engineering	R134a R1234yf		16/25

8.0 Fitting and tubing design best practice

8.1 End form

For a specific end form and detailed information consult the relevant norms or specifications.

8.2 O-ring connection

The O-ring connection is the most common connection. Burgaflex standard is related to the IMACA.

8.2.1 O-ring pilot steel

The O-ring connection end form for steel fittings are produced to Machine Design Standards after plating.

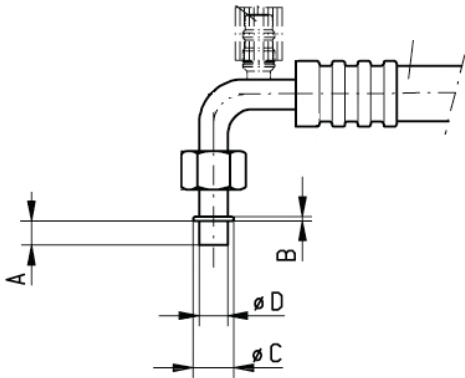

	$\pm 0,4$ A	$+0,45$ $-0,25$ B	$\pm 0,25$ C	0 $-0,13$ D
-06	7,1	1,8/2,5*	13,2	8,56
-08	9,8	1,8/2,5*	16,35	11,71
-10	9,8	2,5	19,47	14,48
-12	9,8	2,5	23,04	17,65



* where 1.24mm material is used

8.2.2 O-ring pilot aluminium

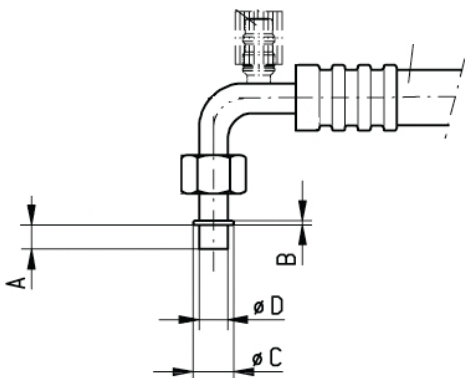
The O-ring connection end form for aluminium fittings are produced to Machine Design Standards



	$\pm 0,4$ A	$+0,45$ $-0,25$ B	$\pm 0,25$ C	0 $-0,13$ D
-06	7,1	2,5	13,2	8,56
-08	9,8	2,5	16,35	11,71
-10	9,8	2,5	19,47	14,48
-12	9,8	2,5	23,04	17,65

	Engineering and Design Best practices for manufacturing (Airconditioning) tubes & hose assemblies					
	Specification nr.	Rev.	Date	Author	Refrigerant	Signature
BUR-SPEC-001	H	13-01-2023	Engineering	R134a R1234yf		17/25

8.2.3 O-ring nut

O ring nuts are manufactured to a standard with Burgaflex inscription at the top. Material SEA 1008

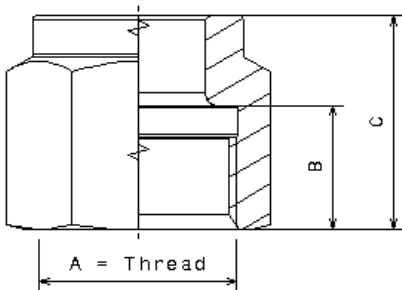

Part number	A Thread	B ±0.1	C ±0.2	HEX
3-9717	5/8" -18UNF-2B	10	18	19
3-9718	3/4" -16UNF-2B	11.5	20.5	22
3-9719	7/8" -14UNF-2B	14.5	24	27
3-9720	1 1/16" -14UNF-2B	17.5	28.5	32



8.2.4 O-ring and Torque

Specification and torque for O rings according table below. Material based on the specification of the airconditioning system. Common material used for a system filled with R134a or R1234yf is EPDM or HNBR.

Burgaflex standard is HNBR.



bestel nr. part no. référence Bestell Nr. parça no	I.D. (mm)	width (mm)	proposed torque (Nm)
7028-06	7.65	1.78	13,6-20,3
7028-08	10.82	1.78	32,5-42,0
7028-10	14.00	1.78	35,3-42,0
7028-12	17.17	1.78	40,7-47,5

		Engineering and Design Best practices for manufacturing (Airconditioning) tubes & hose assemblies				
Specification nr.	Rev.	Date	Author	Refrigerant	Signature	Page
BUR-SPEC-001	H	13-01-2023	Engineering	R134a R1234yf		18/25

9.0 Plating

9.1 Burgaflex standard plating (Cr6free)

Burgaflex standard plating: A Cr(III) dignified blue or iriserende passivation according BURG SPEC 002. (Chr6Free) Layer thickness 8 - 11 µm.

Corrosion behaviour: 96 hours for white rust and 240 hours for red rust after a salt spray test according to DIN 50021SS

9.2 Zink Nickel

At request a zink nickel Fe // ZnNi with A-p passivation according BURG SPEC 002. Layer thickness 8 - 11 µm.

Corrosion behaviour: 240 hours for white rust and 720 hours for red rust after a salt spray test according to DIN 50021SS

Specification nr.	Rev.	Date	Author	Refrigerant	Signature	Page
BUR-SPEC-001	H	13-01-2023	Engineering	R134a R1234yf		19/25

10.0 Dimensions Fittings



10.1 Catalogues

Dimensions of Burgaflex fittings are according to **BURG SPEC 005** and/or airconditioning and Burgaclip catalogues.

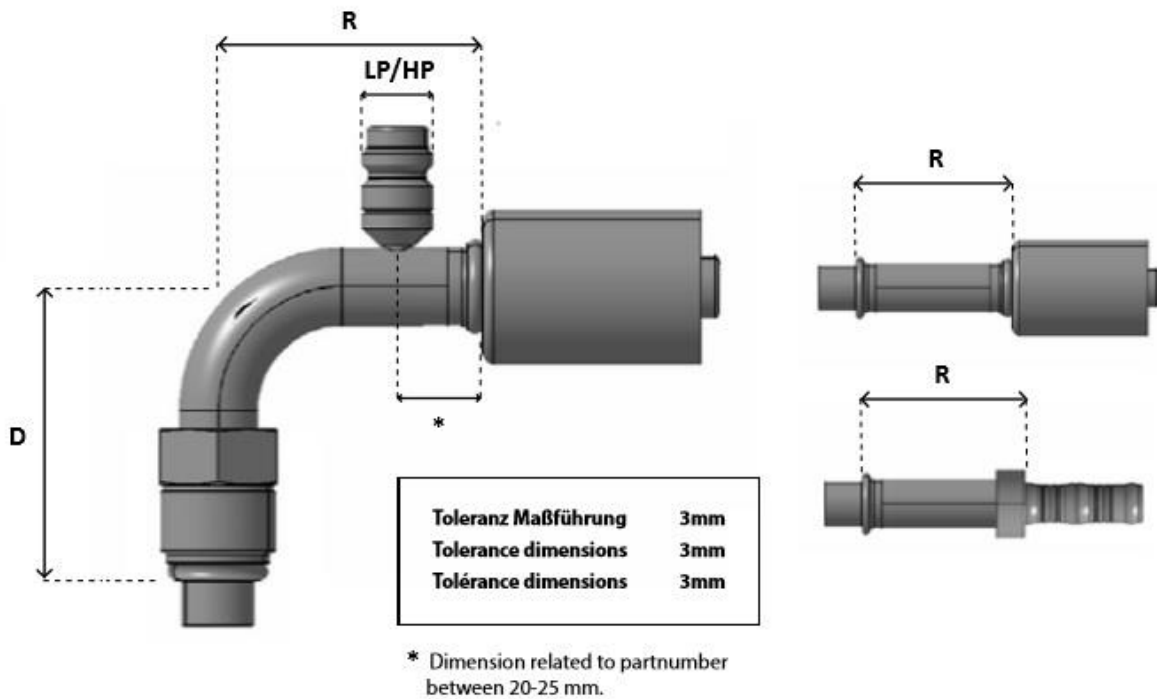
10.2 Run and Drop



The Run and Drop are specified according to figures above.

	Engineering and Design Best practices for manufacturing (Airconditioning) tubes & hose assemblies					
	Specification nr.	Rev.	Date	Author	Refrigerant	Signature
BUR-SPEC-001	H	13-01-2023	Engineering	R134a R1234yf		20/25

10.3. Part numbering

Burgaflex part number is indicated according to the below example. Customer specific part numbers are also related to the similar set up of numbering if applicable.

54704-A-BS (FB)

54 = indication type of fitting.

51 = reusable

52 = crimp fitting for 3055 Standard Barrier Hose

53 = crimp fitting for 3090 Reduced Barrier Hose

54 = Burgaclip fitting

704 = type of fitting – type of connection

-A = Connection size

-B = Hose size

-S = Steel. (A = Aluminium, SS = Stainless Steel)

-FB = Furnish brazing (only for machined parts for production)

A fitting with a valve body can be identified as follow

-With a 13 mm valve (Low Pressure) → 54717-08-08**LPS**

-With a 16 mm valve (High Pressure) → 54717-12-12**HPS**

Standard valve used for 06 and 08 **hose connection** is the 16 mm (HP) High Pressure valve

Standard valve used for 10 and 12 **hose connection** is the 13 mm (LP) Low Pressure valve

Specification nr.	Rev.	Date	Author	Refrigerant	Signature	Page
BUR-SPEC-001	H	13-01-2023	Engineering	R134a R1234yf		21/25

11.0 Hose and crimp design best practice

11.1 Length and tolerances

Unless otherwise specified, overall hose assembly length tolerance is until 300 mm + 5% and - 5%.
 Above 300 mm length the overall hose assembly length tolerance is +2 and -1 %

11.2 Hose length specification

The hose length can be specified in various ways, see examples below.

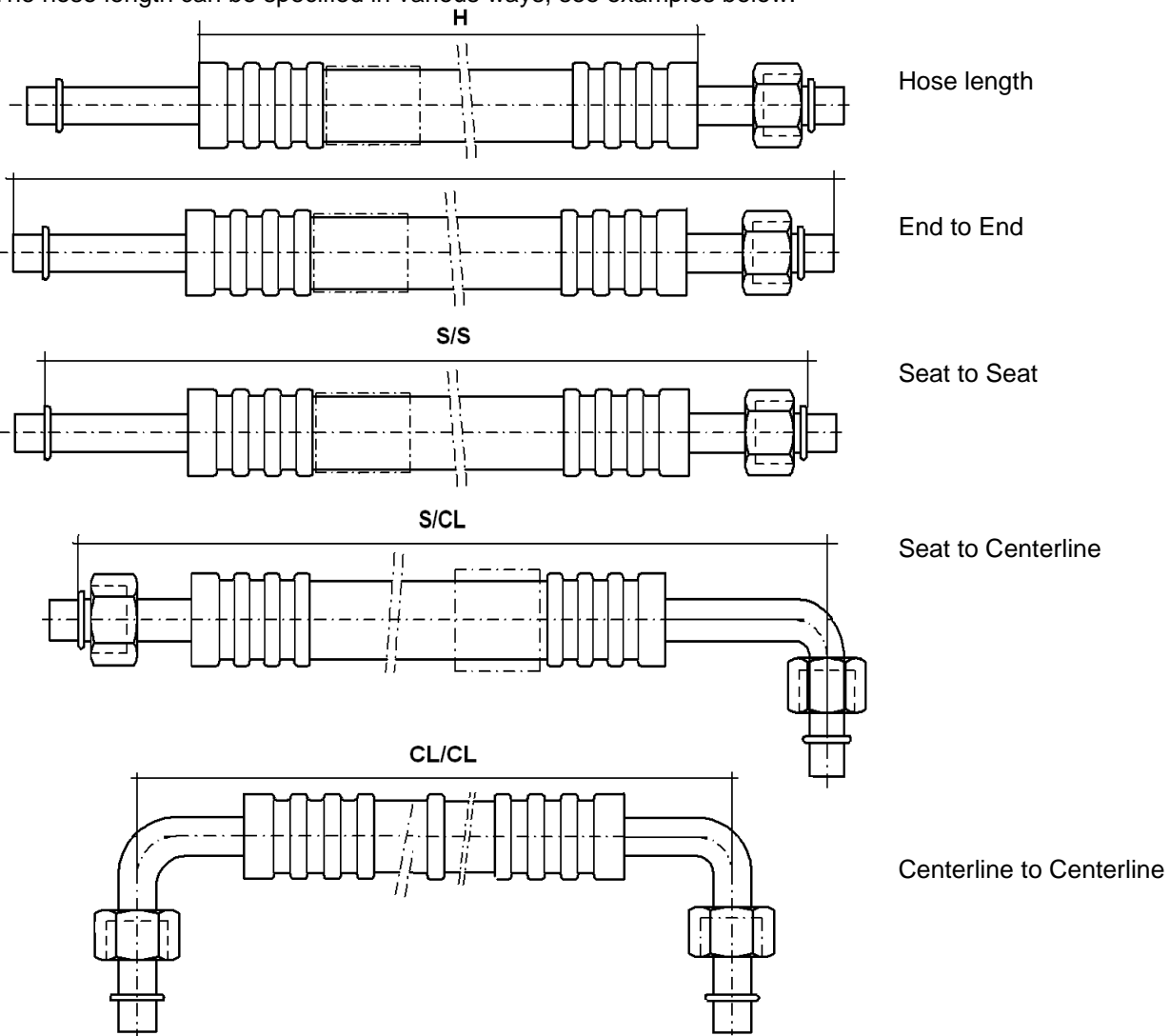

Specification nr.	Rev.	Date	Author	Refrigerant	Signature	Page
BUR-SPEC-001	H	13-01-2023	Engineering	R134a R1234yf		22/25

11.3 Crimping

Due to the general construction of a hose crimping machine there are 2 considerations which should both be respected in the design of hose fittings. If only one of these considerations is respected while the other is not, it will not be possible to crimp the fitting on the hose. Burgaflex uses, among other crimping machines, a crimper which minimizes these considerations, called an open crimper or side feed crimper.

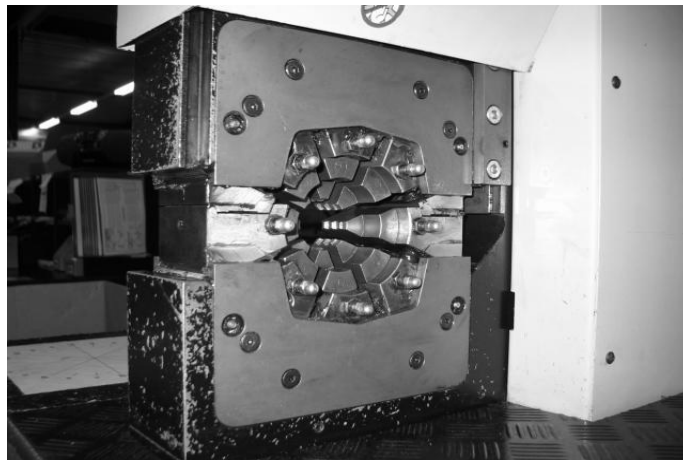

Is the minimal distance (L1) between the centerline of the crimping jaws (C) and the edge of the machine. See figure below For the design of the fitting this means: the minimal distance (L1) between the centerline of the fitting and the inside of the opposite of the bend.

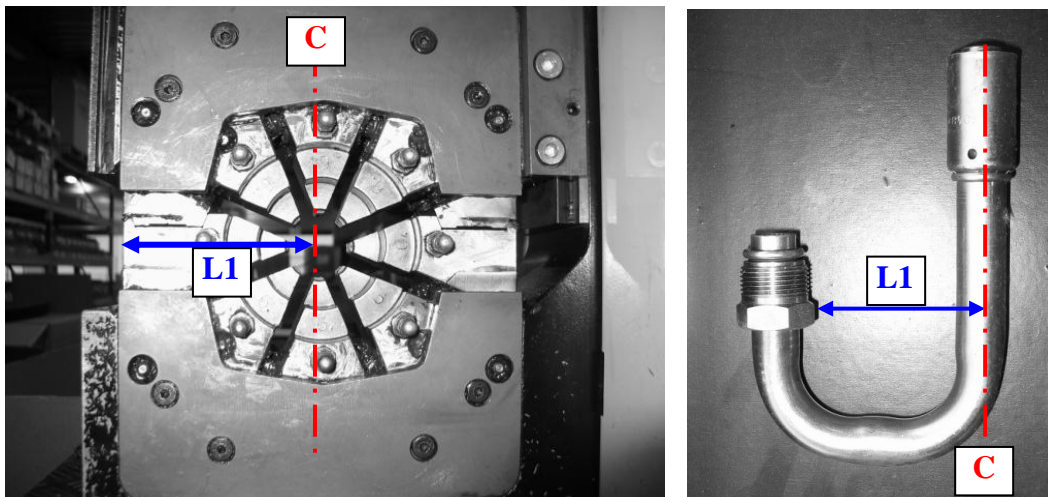

Distance L1 should be at least 120 mm.

Burgaflex		Engineering and Design Best practices for manufacturing (Airconditioning) tubes & hose assemblies				
Specification nr.	Rev.	Date	Author	Refrigerant	Signature	Page
BUR-SPEC-001	H	13-01-2023	Engineering	R134a R1234yf		23/25

Is the distance (L2) between the end (E1) of the crimping jaws and the edge (E2) of the crimping area of the machine. See figures below. For the design of the fitting this means: the minimal straight end of the pipe (L2) between the crimp ferrule and the start of the first bend. See figures below.

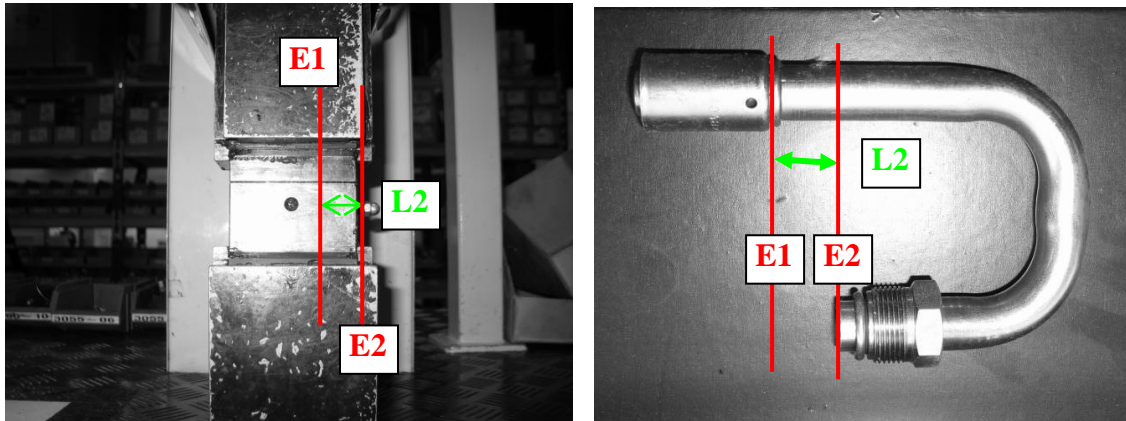

Distance L2 should be at least: 25 mm.

Each subsidiary can have slightly deviations. Please ask your local engineers.

11.4 Indicate the angle between 2 fittings on a drawing

At Burgaflex we indicate the angle between 2 fitting on a hose as shown in the figures below. It would be recommended to use this indication on the drawing. Our production works according to the Burgaflex standard and if the drawing is differently set up it could cause confusion.

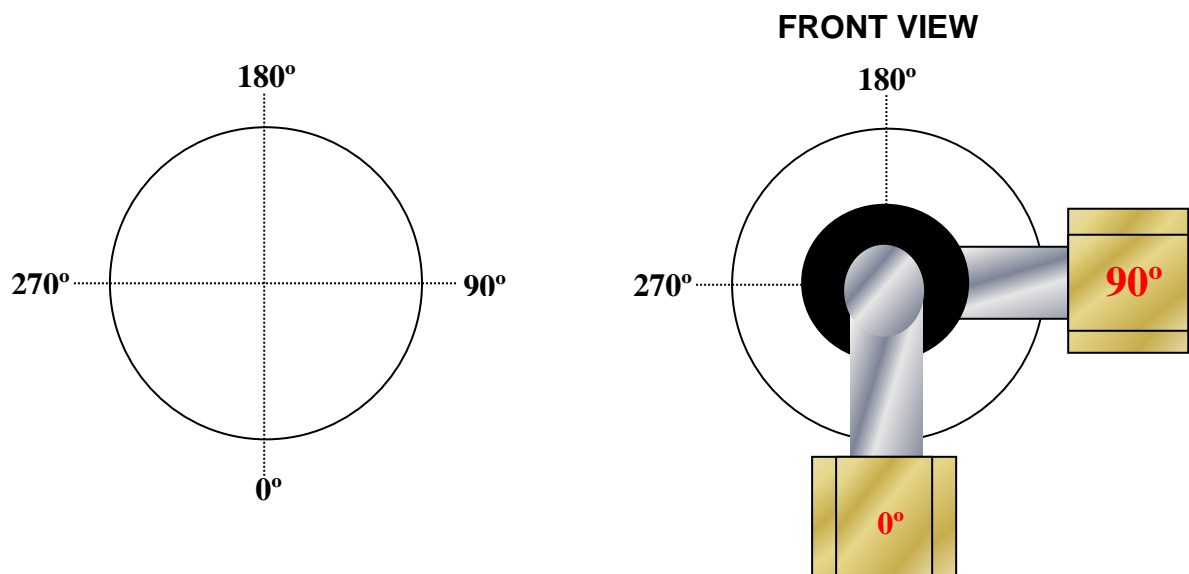



Figure above shows the angle indicator we use. In practice this means: keep one fitting towards yourself with the connection facing downwards. Then read the angle of the other fitting according the angle indicator. When looking to the figure at the right, this means the angle here is: 90°.

		Engineering and Design Best practices for manufacturing (Airconditioning) tubes & hose assemblies				
Specification nr.	Rev.	Date	Author	Refrigerant	Signature	Page
BUR-SPEC-001	H	13-01-2023	Engineering	R134a R1234yf		24/25

12.0 Validation and quality control tests

All Burgaflex airconditioning hose assemblies meets to SAE J2064 rev 2015, ISO 8866-2 specifications. Additional crimped with a fitting or Burgaclip® Burgaflex performs the following standard tests before the release of the product. The internal laboratory can provide customer specific test for approval.

12.1 Burst pressure test

At ambient temperature the hose assembly will be tested for 5 minutes at working pressure and two times working pressure of 35 bar. The fitting must stay on the hose at 4 times working pressure or the hose must blow.

12.2 Coupling integrity test

Test per SAE J2064 paragraph 5.3 and ISO 8866-2. No sample may exceed 10 gramms total weight loss upon completion of the coupling integrity test. The average total weight loss of the six samples must not exceed 7 gramms at the end of a cycle. A seventh sample shall be used as a control sample to compensate the loss of weight of the hose during the test. After each cycle the samples will be bend by 15 degrees in two planes. No hissing or visible oil loss may occur.

12.3 Corrosion resistance test

Fittings and tubing are tested according DIN 50021.

Burgaflex standard: >96 hours white rust and > 240 hours red rust

12.4 Cleanliness test



Test per BUR-SPEC 009. The contamination in a hose assembly and tubinh may not exceed 270 mg/m² when flushed with solvent. Metal particles must be < 250 µm.

13.0 Identification

Each hose assembly is labelled. Burgaflex standard label has the following information

- Burgaflex BV
- Part number customer
- Production date

Each first of a batch has an extra label with EPK written on it. After control and for release of batch production this label is signed by the quality manager or his replacer. The LPK label defines the end of the production run and checked.

		Engineering and Design Best practices for manufacturing (Airconditioning) tubes & hose assemblies				
Specification nr.	Rev.	Date	Author	Refrigerant	Signature	Page
BUR-SPEC-001	H	13-01-2023	Engineering	R134a R1234yf		25/25

14.0 Leak test

14.1 Burgaflex standard

Leak tests in production for steel part with a brazing are only performed on customer's request. This request carries an additional fee at the sales price. Leak tests in production for aluminium parts with a brazing are standard.

14.2 Process of testing

Leak tests with hose assemblies are carried out at 10 bar with a former gas under water. During 20 seconds of pressure no bubbles may occur at the brazing points or hose connections.

Leak tests with aluminium tubing or fittings are carried out at 30 bar with a former gas under water. During 20 seconds of pressure no bubbles may occur at the brazing points

15.0 Engineering

15.1 CAD system

Burgaflex make use of the CATIA CAD system. Standard CAD files as STEP can be used. 3D models are available on request.

The latest version of CATIA is: V5-6R2015.